

※請在答案卡內作答

- In the following questions,  $i$  is  $\sqrt{-1}$ ;  $\delta(t)$  is the Dirac delta function;  $f_c$  is the carrier frequency;

$$u(t) = \begin{cases} 0, & t < 0; \\ \frac{1}{2}, & t = 0; \\ 1, & t > 0 \end{cases}$$

is the unit step function;  $\text{Re}\{\cdot\}$  and  $\text{Im}\{\cdot\}$  denote the operations of taking the real part and imaginary part, respectively;  $1\{\cdot\}$  is the set indicator function; WSS stands for wide-sense stationary; PSD stands for power spectra density; LTI stands for linear time-invariant.

- 本部分測驗試題為單選題(答案只有一個)，請選出正確或最適當的答案，並請用2B鉛筆作答於答案卡。
- 共八題，每題完全答對得五分，答錯倒扣該題分數1/5。

一、 Let  $x(t)$  and  $y(t)$  be two real-valued zero-mean random processes. Suppose that  $x(t)$  and  $y(t)$  are jointly WSS. Let  $h_1(t)$  and  $h_2(t)$  be respectively the (real-valued) impulse responses of two LTI filters. Denote by  $u(t)$  the output random process due to input  $x(t)$  and filter  $h_1(t)$ . Similarly, denote by  $v(t)$  the output random process due to input  $y(t)$  and filter  $h_2(t)$ . Which of the following statement is wrong?

- (A)  $u(t)$  is WSS.
- (B)  $u(t)$  and  $v(t)$  are jointly WSS.
- (C) The sum process  $x(t) + y(t)$  is WSS.
- (D) The sum process  $x(t) + u(t)$  is WSS.
- (E)  $x(t) \cos(2\pi f_c t)$  is WSS.

參考用

注意：背面有試題

※請在答案卡內作答

- 二、 For the transmission system below, we assume that  $b_k \in \{0, 1\}$ ,  $a_k = 2b_k - 1$  and  $s(t) = \sum_{n=-\infty}^{\infty} a_k \cdot g(t - nT)$ . Denote respectively by  $G(f)$ ,  $H(f)$  and  $C(f)$  the Fourier transforms of impulse responses  $g(t)$ ,  $h(t)$  and  $c(t)$ .

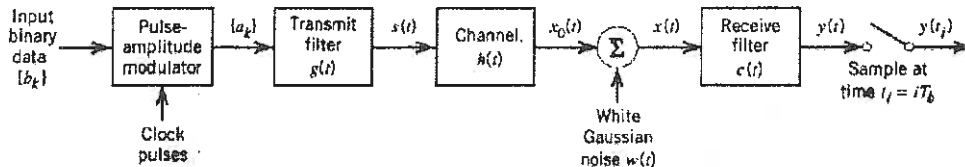

Which of the following statement is wrong?

- (A) Inter-symbol interference can be eliminated if

$$\frac{1}{T} \sum_{n=-\infty}^{\infty} G\left(f - \frac{n}{T}\right) H\left(f - \frac{n}{T}\right) C\left(f - \frac{n}{T}\right) = 1.$$

This is named the Nyquist Criterion.

- (B) For given  $G(f)$  and known  $H(f)$ ,

$$C(f) = G^*(f)H^*(f) \exp\{-i2\pi fT\}$$

is a matched filter that maximizes the output SNR.

- (C) For given  $G(f)$  and known  $H(f)$ ,

$$C(f) = \frac{Q^*(f)}{S_q(f) + N_0/2}$$

is a minimum mean-square error (MMSE) equalizer, where  $Q(f) = G(f)H(f)$  and

$$S_q(f) = Q^*(f) \left( \frac{1}{T} \sum_{k=-\infty}^{\infty} Q\left(f - \frac{k}{T}\right) \right).$$

- (D) Derivation of the Nyquist Criterion ignores entirely the effect of noise  $w(t)$ ; thus, it may induce the so-called noise enhancement phenomenon. In order to alleviate the noise enhancement phenomenon, it is better to simultaneously consider inter-symbol interference and channel noise at the design stage. This results in the design of MMSE equalizer. By this, we conclude that the MMSE filter design is reduced to a Nyquist filter design when no noise is present, i.e.,  $w(t) = 0$ .
- (E) It is possible to design  $C(f)$  that is a matched filter to  $G(f)H(f)$  in (B) and that is also an MMSE equalizer in (C) since both consider the noise effect at their design stage.

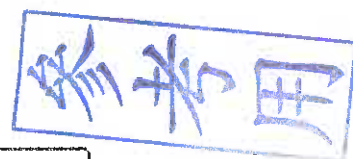

注意：背面有試題

※請在答案卡內作答

三、

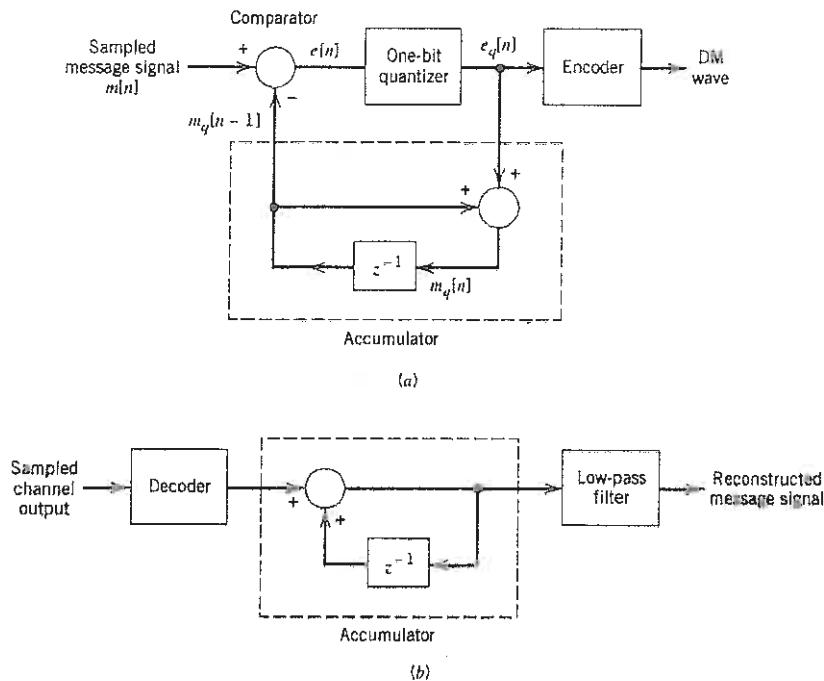

參考用

In the delta modulation system shown above,  $m[n] = m(nT_s)$  is the  $n$ th sample of waveform  $m(t)$  with sampling period  $T_s$ , and

$$e_q[n] = \begin{cases} \Delta, & \text{if } e[n] \geq 0; \\ -\Delta, & \text{if } e[n] < 0, \end{cases}$$

We assume  $m[0] = m_q[0] = 0$  and  $m_q[n] = \sum_{i=1}^n e_q[i]$ . Which of the following statement is wrong?

- (A) The quantization error  $e[n] - e_q[n]$  is less than the signal error  $m[n] - m_q[n]$ .
- (B) If  $0 < m(t) < \Delta$  for every  $t > 0$ , then the sequence  $\{e_q[n]\}_{n=1}^{\infty}$  will alternate between  $\Delta$  and  $-\Delta$ .
- (C) Slope overload distortion can be removed by choosing  $\Delta$  to satisfy the slope overload condition:

$$\frac{\Delta}{T_s} \geq \max_t \left| \frac{dm(t)}{dt} \right|.$$

- (D) Under the slope overload condition in (C),  $|m[1] - m_q[1]| \leq \Delta$ .
- (E) The signal error is no larger than  $\Delta$ , i.e.,  $|m[n] - m_q[n]| \leq \Delta$  if slope overload condition in (C) is satisfied, which can be proved by induction.

注意：背面有試題

※請在答案卡內作答

四、 A type II correlative-level coding scheme is shown below, where

$$H_{\text{Nyquist}}(f) = \begin{cases} 1, & \text{if } |f| < \frac{1}{2T_b}; \\ 0, & \text{otherwise} \end{cases}$$

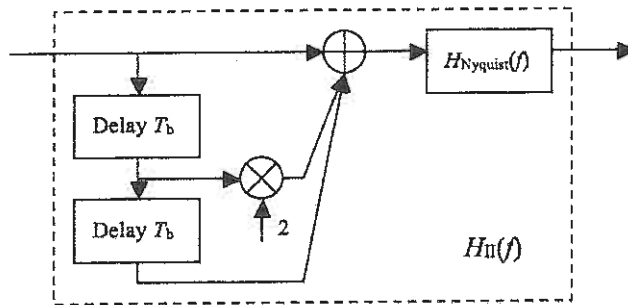

Which of the following statement is wrong?

- (A) If  $x(t)$  is fed into  $H_{\text{II}}(f)$ , then the signal at the input of  $H_{\text{Nyquist}}(f)$  is  $x(t) + 2x(t - T_b) + x(t - 2T_b)$ .
- (B)  $H_{\text{II}}(f) = H_{\text{Nyquist}}(f)[1 + 2 \exp(-i2\pi fT_b) + \exp(-i4\pi fT_b)]$
- (C)  $H_{\text{II}}(f) = H_{\text{I}}(f)H_{\text{I}}(f)$ , where  $H_{\text{I}}(f)$  is the transfer function of the type I correlative-level coding scheme below.

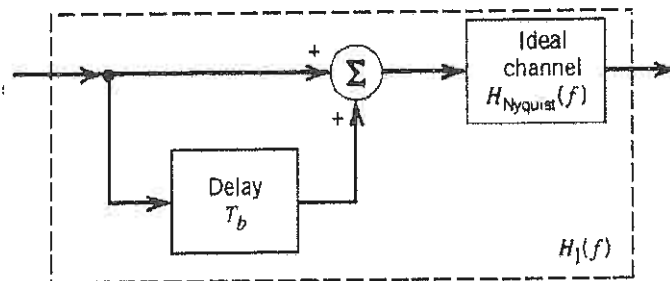

- (D) The type I correlative-level coding scheme is also referred to as duo-binary signaling because by sampling at every  $T_b/2$  seconds (i.e., doubling the sampling rate), inter-symbol interference can be avoided.
- (E) Without additional technique such as precoding, error propagation may occur due to the introduction of correlative-level coding scheme such as  $H_{\text{I}}(f)$ .

物 考 用

注意：背面有試題

※請在答案卡內作答

五、 Consider OFDM modulation with FFT size of 1024 and OFDM symbol period of  $10 \mu s$ . The cyclic prefix length is  $2.5 \mu s$ . Trellis-coded modulation (with a rate  $2/3$  convolutional code and  $8$ -PSK) is used to modulate all the OFDM subcarriers. The transmission (information) data rate (measured in *bps*) and transmission bandwidth (measured in *MHz*) of this OFDM modulation scheme are about:

- (A) 200 Mbps and 100 MHz. (B) 160 Mbps and 100 MHz. (C) 200 Mbps and 80 MHz.  
(D) 160 Mbps and 80 MHz. (E) 200 Mbps and 160 MHz.

六、 Following above problem and assume the OFDM signal is transmitted at a center carrier frequency of 10 GHz in a free space channel with AWGN (at room temperature) with the following system parameters: (given that  $10 \log_{10} \pi \approx 5$ , the thermal noise power in 1 Hz receiver bandwidth at room temperature is  $-174$  dBm, and 1 mW is 0 dBm)

Transmitter antenna gain: 6 dB  
Receiver antenna gain : 6 dB  
Transmitter receiver distance : 300 m  
Receiver front-end noise figure : 6 dB  
Required SNR for each subcarrier : 6 dB

The minimum transmit power  $P_t$  needed is about:

- (A) 8 dBm. (B) 16 dBm (C) 24 dBm (D) 32 dBm. (E) 40 dBm.

七、 Consider a direct sequence spread spectrum BPSK system using a binary PN sequence for spreading. Which of the following statements are true?

- (A) The balance property of a PN sequence means that in a period of the PN sequence the number of 0's is equal to the number of 1's.  
(B) The processing gain of a direct sequence spread spectrum system is larger when the period of the PN sequence (the spreading code period) is larger.  
(C) A direct sequence spread spectrum system has a 40 dB "jamming margin" means that the jammer-power to the desired-signal-power ratio is 40 dB at the input of the receiver.  
(D) Given that the processing gain of the direct sequence spread spectrum BPSK system is 20 dB, and the system is interfered by a single-tone in-band jammer with average  $(SNR)_I = -10$  dB at the input of the receiver, then the average  $(SNR)_O = 10$  dB at the output of the receiver.  
(E) None of the above are true.

八、 Consider link budget for radio communication. Which of the following statements are true?

- (A) The power gain of an antenna is linearly proportional to the carrier wavelength.  
(B) The beam width of an antenna is linearly proportional to the power gain.  
(C) The equivalent noise temperature of a device is linearly proportional to the noise figure of the device.  
(D) A transmitter transmits more power when a link margin is reserved for the link budget.  
(E) None of the above are true.

注意：背面有試題

參考用

※請在答案卡內作答

- 本部份測驗試題為複選題(答案可能有一個或多個)，請選出所有正確或最適當的答案，並請用 2B 鉛筆作答於答案卡。
- 共十二題，每題完全答對得五分，答錯不倒扣。

九、 Consider BPSK and QPSK modulation in the same AWGN channel. Which of the following statements are true?

- (A) At same  $E_b/N_0$  and same data rate (measured in *bits per second, bps*), BPSK and QPSK have the same bit error rate.
- (B) At same  $E_b/N_0$  and QPSK data rate (measured in *bps*) is twice of BPSK data rate, BPSK is better than QPSK in bit error rate.
- (C) At same transmission power level and same data rate (measured in *bps*), BPSK and QPSK have the same bit error rate.
- (D) At same transmission power level and QPSK data rate (measured in *bps*) is twice of BPSK data rate, BPSK is better than QPSK in bit error rate.
- (E) None of the above are true.

十、 Consider MSK (minimum shift keying) modulation in an AWGN channel. Which of the following statements are true?

- (A) An MSK signal is a continuous phase BFSK signal with two signaling frequencies separated by  $1/T_b$ , where  $T_b$  is the bit period.
- (B) During each bit time, the phase trellis of an MSK signal increases or decreases by  $\pi/2$ .
- (C) A coherent receiver is required to demodulate an MSK signal.
- (D) MSK is better than QPSK in bandwidth efficiency (measured in *bps/Hz*).
- (E) None of the above are true.

十一、 Consider DPSK in an AWGN channel. Which of the following statements are true?

- (A) DPSK is an example of noncoherent orthogonal modulation.
- (B) A DPSK receiver works well with a small carrier frequency offset.
- (C) DPSK needs 3 dB more  $E_b/N_0$  to perform as good as coherent BPSK in bit error rate.
- (D) DPSK needs 3 dB less  $E_b/N_0$  to perform as good as noncoherent BFSK in bit error rate.
- (E) None of the above are true.

十二、 Consider noncoherent  $M$ 'ary FSK. Which of the following statements are true?

- (A) The frequency separation between any two different signaling frequencies needs to be at least a non-zero integer multiples of  $1/T_s$ , where  $T_s$  is the symbol time.
- (B) As  $M$  increases, this modulation scheme becomes less bandwidth efficient.
- (C) As  $M$  increases, this modulation scheme becomes more power efficient.
- (D) Gray encoding at transmitter improves the data detection performance of this scheme.
- (E) None of the above are true.

注意：背面有試題

參考用



※請在答案卡內作答

- 十三、 Consider linear block code and its decoding for data transmission in a discrete memoryless channel. Which of the following statements are true?
- (A) When a zero error syndrome vector is found at a receiver, the received code word is correct.
  - (B) When a non-zero error syndrome vector is found at a receiver, the received code word is incorrect.
  - (C) The error correction capability of a linear block code is determined by the average Hamming weight of all the non-zero code words.
  - (D) Each coset leader in the standard array has the maximum Hamming weight in the coset.
  - (E) None of the above are true.
- 十四、 Consider the Shannon information capacity theorem and its implications. Which of the following statements are true?
- (A) According to the Shannon information capacity theorem, the capacity of a band-limited AWGN channel is increased about 10 times if the SNR is increased 1000 times.
  - (B) A relationship between bandwidth efficiency ( $C/B$ : capacity over transmission bandwidth, measured in  $bps/Hz$ ) and the  $E_b/N_0$  needed for error free transmission in an AWGN channel can be derived as  $E_b/N_0 = 2^{(C/B)} - 1$  from the Shannon information capacity theorem for an ideal digital communication system.
  - (C) Error free transmission is possible at  $E_b/N_0 = 0$  dB when the bandwidth efficiency approaches 1 for an ideal digital communication system in AWGN channel.
  - (D) Error free transmission is possible at  $E_b/N_0 = -1.6$  dB when the bandwidth efficiency approaches 0 for an ideal digital communication system in AWGN channel.
  - (E) None of the above are true.

參考用

注意：背面有試題

※請在答案卡內作答

十五、 Let  $X(f)$  and  $\tilde{X}(f)$  be the Fourier transforms of real random process  $x(t)$  and complex random process  $\tilde{x}(t)$ , respectively, where  $x(t) = \text{Re}\{\tilde{x}(t) \exp(i2\pi f_c t)\}$ . Denote by  $x_{2T}(t) = x(t) \cdot \mathbf{1}\{|t| < T\}$  the truncated random process of  $x(t)$ . Denote the Fourier transform of  $x_{2T}(t)$  as  $X_{2T}(f)$ . Which of the following statements are true?

(A) The PSD of  $x(t)$  is

$$S_x(f) = \frac{1}{2T} E[X_{2T}(f)X_{2T}(-f)]$$

for any  $T$ , if  $x(t)$  is WSS.

(B) Under the additional assumption that  $\tilde{x}(t)$  and  $x(t)$  are both deterministic,  $\tilde{x}(t)$  uniquely determines  $x(t)$ , but there exists a  $\tilde{y}(t)$  such that  $\tilde{x}(t) \neq \tilde{y}(t)$  and  $x(t) = \text{Re}\{\tilde{y}(t) \exp(i2\pi f_c t)\}$ .

(C) With probability one,  $\tilde{x}(t) = \int_{-\infty}^{\infty} 2 \cdot X(f+f_c) \cdot u(f+f_c) \exp(i2\pi ft) df$ .

(D) Suppose  $x(t)$  is WSS. Let  $\tilde{x}_I(t) = \text{Re}\{\tilde{x}(t)\}$  and  $\tilde{x}_Q(t) = \text{Im}\{\tilde{x}(t)\}$ . Then, if  $\tilde{x}_I(t)$  and  $\tilde{x}_Q(t)$  are jointly WSS, then their product process has zero mean, i.e.,  $E[\tilde{x}_I(t)\tilde{x}_Q(t)] = 0$ .

(E) Suppose  $\tilde{x}(t)$  is real-valued. Then, it cannot be true that both  $x(t)$  and  $\tilde{x}(t)$  are zero-mean WSS.

十六、 Formulate the signals of different modulations as follows:

$$s_{\text{DSB-C}}(t) = [1 + k_a m(t)] \cos(2\pi f_c t);$$

$$s_{\text{DSB-SC}}(t) = m(t) \cos(2\pi f_c t);$$

$$s_{\text{SSB}}(t) = m(t) \cos(2\pi f_c t) - \hat{m}(t) \sin(2\pi f_c t);$$

$$s_{\text{VSB}}(t) = m(t) \cos(2\pi f_c t) - m'(t) \sin(2\pi f_c t),$$

where  $M'(f) \triangleq M(f)[-H_Q(f)]$  with  $H_Q(f)$  satisfying (i)  $H_Q(-f) = H_Q^*(f)$  and

$$(ii) \frac{1}{2} H_Q(f) = \begin{cases} 1, & f \leq -f_v \\ \text{some value} \in (0, 1), & -f_v < f < 0 \\ 0, & f = 0 \end{cases}$$

and  $\hat{M}(f) = \lim_{f_v \downarrow 0} M'(f)$ . Here,  $M(f)$ ,  $\hat{M}(f)$  and  $M'(f)$  denote the Fourier transforms of  $m(t)$ ,  $\hat{m}(t)$  and  $m'(t)$ , respectively. Two candidate demodulators for the demodulation of these modulated signals are envelop detector and coherent detector, of which the structures are depicted below.

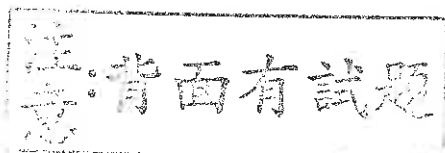
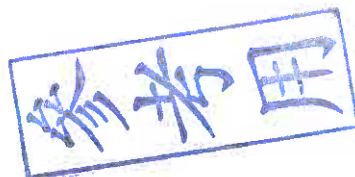



※請在答案卡內作答

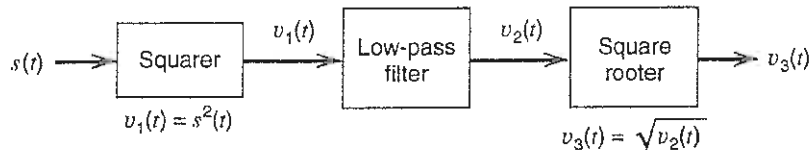

(a) envelop detector

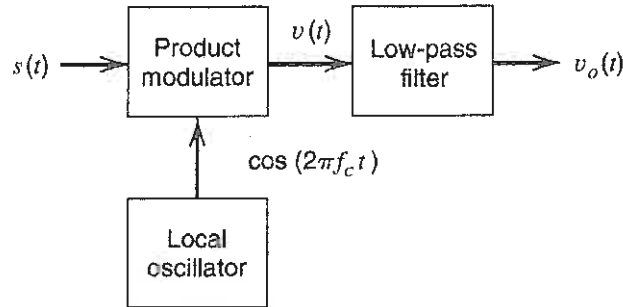

(b) coherent detector

參考用

The lowpass filter in the above diagrams are assumed ideal, which can filter out all high frequency terms with parameter  $f_c$ , such as  $m^2(t) \cos(4\pi f_c t)$ ,  $\hat{m}^2(t) \cos(4\pi f_c t)$ ,  $m(t)\hat{m}(t) \sin(4\pi f_c t)$ ,  $\cos(4\pi f_c t)$ ,  $m(t) \cos(4\pi f_c t)$  and  $m'(t) \sin(4\pi f_c t)$ , and pass all terms without parameter  $f_c$ , such as  $m^2(t)$ ,  $\hat{m}^2(t)$ ,  $m(t)$  and  $m'(t)$ . Answer which of the following statements are true.

- (A)  $m(t)$  can be recovered from DSB-SC modulated signal by envelop detector if  $m(t) > 0$ .
- (B)  $m(t)$  generally cannot be recovered from SSB modulated signal by envelop detector.
- (C) A DC-free  $m(t)$  can be recovered from DSB-C modulated signal by coherent detector plus a DC remover even if  $k_a|m(t)| > 1$  for some  $t$ .
- (D)  $m(t)$  can be recovered from VSB modulated signal by coherent detector.
- (E) Coherent detector can be used to recover all four modulated signals.

背面有試題

※請在答案卡內作答

十七、 The SSB modulated signal can be formulated as

$$s(t) = m(t) \cos(2\pi f_c t) - \hat{m}(t) \sin(2\pi f_c t),$$

where  $\hat{m}(t)$  is the Hilbert transform of  $m(t)$  (with the transfer function given in the previous problem). We assume that  $m(t)$  is band-limited with bandwidth  $W$ , and  $W$  is less than the carrier frequency  $f_c$ . The signal  $s(t)$  is fed into the system that suffers additive white noise  $w(t)$  with one-sided PSD  $N_0$  as shown below:

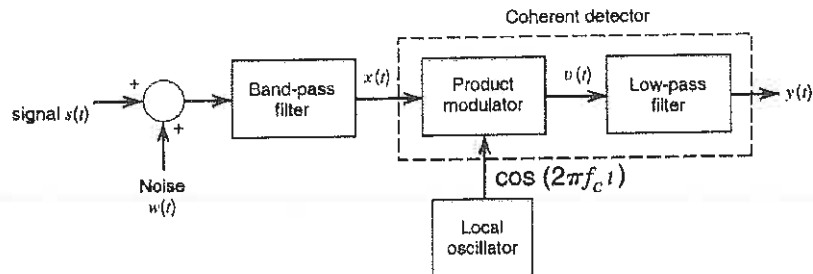

Here, we assume that the bandpass filter is ideally equal to 1 for those  $f$ 's in the signal transmission bandwidth, and zero, otherwise. Also, the lowpass filter is ideal, passing only the signals in the message bandwidth. Then, which of the following statements are true?

- (A) The Hilbert transform of  $\cos(2\pi f_c t)$  is  $\sin(2\pi f_c t)$ .
- (B) The Hilbert transform of  $m(t) \cos(2\pi f_c t)$  is  $\hat{m}(t) \sin(2\pi f_c t)$ .
- (C) It is possible that  $\hat{m}(t) = m(t)$  and  $\lim_{T \rightarrow \infty} \frac{1}{2T} \int_{-T}^T m^2(t) dt > 0$ .
- (D) The output signal-to-noise ratio as seen by  $y(t)$  is equal to  $\frac{P}{WN_0}$ , where  $P$  is the average power of  $m(t)$ .
- (E) The figure-of-merit of the system is less than one.

參考用

注意：背面有試題

※請在答案卡內作答

十八、 An FM system with pre-emphasis and de-emphasis filters is illustrated below, where  $m(t) = 2 \cos(2\pi f_m t)$  is a single-tone signal.

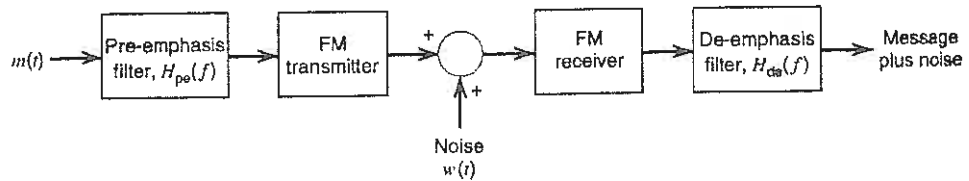

With the pre-emphasis filter, the FM modulated signal becomes

$$s_{FM}(t) = \cos \left( 2\pi f_c t + 2\pi k_f \int_0^t m_{pe}(\tau) d\tau \right),$$

where  $m_{pe}(t)$  is the output due to input  $m(t)$  and filter  $H_{pe}(f)$ . Which of the following statements are true?

- (A) The instantaneous frequency of the FM system is given by  $f_i(t) = f_c + k_f m_{pe}(t)$ .
- (B) The spectrum of the output of the pre-emphasis filter is given by  $M_{pe}(f) = H_{pe}(f_m)\delta(f - f_m) + H_{pe}(-f_m)\delta(f + f_m)$ .
- (C) The maximum frequency derivation  $(\Delta f)_{pe}$  of the instantaneous frequency of the FM system is unchanged if the impulse response of the pre-emphasis filter is real-valued.
- (D) The modulation index  $\beta_{pe}$  of the pe/de-emphasis FM system is unchanged if the impulse response of the pre-emphasis filter is real-valued.
- (E) If the PSD of the noise at the FM receiver output is  $S_{N_o}(f)$ , then the de-emphasis filter can improve the output SNR by

$$I = \frac{\int_{-f_m}^{f_m} S_{N_o}(f) df}{\int_{-f_m}^{f_m} S_{N_o}(f) |H_{de}(f)|^2 df} \text{ dB,}$$

provided that  $H_{pe}(f)H_{de}(f) = 1$ .

參考用

注意：背面有試題

※請在答案卡內作答

十九、 Denote by  $\langle x(t), y(t) \rangle$  the inner product of two real signals  $x(t)$  and  $y(t)$ , satisfying

$$\begin{cases} (i) \langle x(t), x(t) \rangle \geq 0, \text{ and } \langle x(t), x(t) \rangle = 0 \Leftrightarrow x(t) = 0; \\ (ii) \langle x(t) + z(t), y(t) \rangle = \langle x(t), y(t) \rangle + \langle z(t), y(t) \rangle; \\ (iii) \langle a \cdot x(t), y(t) \rangle = a \cdot \langle x(t), y(t) \rangle; \\ (iv) \langle x(t), y(t) \rangle = \langle y(t), x(t) \rangle. \end{cases}$$

Let  $\{f_k(t)\}_{k=1}^{\infty}$  be a series of real functions satisfying

$$\langle f_i(t), f_j(t) \rangle = \begin{cases} 1, & i = j; \\ 0, & i \neq j. \end{cases}$$

Which of the following statements are true?

(A) For two deterministic real functions  $u(t)$  and  $v(t)$ , if  $\langle u(t), v(t) \rangle = 0$ , then the two sets,  $\{k : \langle u(t), f_k(t) \rangle \neq 0\}$  and  $\{k : \langle v(t), f_k(t) \rangle \neq 0\}$ , are disjoint.

(B) For a deterministic real function  $s(t)$ , let

$$e(t) = s(t) - \sum_{k=1}^{\infty} a_k \cdot f_k(t).$$

Then, setting  $\{a_k = \langle s(t), f_k(t) \rangle\}_{k=1}^{\infty}$  minimizes  $\langle e(t), e(t) \rangle$ .

(C) For a real-valued random process  $s(t)$ , define

$$e(t) = s(t) - \sum_{k=1}^{\infty} a_k f_k(t).$$

Then,  $E[e^2(t)]$  is minimized by the assignment of  $\{a_k = \langle s(t), f_k(t) \rangle\}_{k=1}^{\infty}$ .

(D) Pass the signal  $s(t)$  through a LTI filter with impulse response  $h(t)$ .

Let  $u(t)$  be the filter output. Suppose

$$s(t) = \sum_{i=1}^{\infty} a_i \cdot f_i(t) \text{ and } h(t) = \sum_{j=1}^{\infty} b_j \cdot f_j(t).$$

Then,  $U(f) = \sum_{i=1}^{\infty} \sum_{j=1}^{\infty} a_i b_j F_i(f) F_j(f)$ , where  $U(f)$  and  $F_i(f)$  are the Fourier transforms of  $u(t)$  and  $f_i(t)$ .

(E) If  $n(t)$  is a zero-mean white Gaussian random process, and  $n(t) = \sum_{i=1}^{\infty} a_i f_i(t)$  with  $a_i = \langle n(t), f_i(t) \rangle$ , then  $\{a_i\}_{i=1}^{\infty}$  is independent and identically distributed, provided that the inner product is defined as  $\langle x(t), y(t) \rangle \triangleq \int_{-\infty}^{\infty} x(t)y(t)dt$ .



注意：背面有試題

※請在答案卡內作答

- 二十、 Denote by  $\langle x(t), y(t) \rangle$  the inner product of two real signals  $x(t)$  and  $y(t)$ , which satisfies the four properties stated in the previous problem. Again, let  $\{f_k(t)\}_{k=1}^{\infty}$  be a series of real functions satisfying

$$\langle f_i(t), f_j(t) \rangle = \begin{cases} 1, & i = j; \\ 0, & i \neq j. \end{cases}$$

Which of the following statements are true?

- (A) Let  $\langle s(t), s(t) \rangle$  be defined as the energy of the signal  $s(t)$ . Then, the energy of  $s(t)$  is equal to  $\sum_{i=1}^{\infty} a_i^2$ , where  $a_i = \langle s(t), f_i(t) \rangle$ .
- (B) Let  $\mathbf{a} = (a_1, a_2, \dots, a_m)$  and  $\mathbf{b} = (b_1, b_2, \dots, b_m)$ . Define the inner product between  $\mathbf{a}$  and  $\mathbf{b}$  as  $[\mathbf{a}, \mathbf{b}] = \sum_{i=1}^m a_i b_i$ . Suppose  $u(t) = \sum_{i=1}^m a_i f_i(t)$  and  $v(t) = \sum_{i=1}^m b_i f_i(t)$ . Then,  $\langle u(t), v(t) \rangle = [\mathbf{a}, \mathbf{b}]$ .
- (C) If  $\{f_i(t)\}_{i=1}^{\infty}$  is a complete basis for the signal space containing  $r(t)$ ,  $s(t)$  and  $n(t)$ . Then,  $r(t) = s(t) + n(t)$  can be transformed equivalently to  $r_i = s_i + n_i$  for  $i = 1, 2, 3, \dots$  with  $r_i = \langle r(t), f_i(t) \rangle$ ,  $s_i = \langle s(t), f_i(t) \rangle$  and  $n_i = \langle n(t), f_i(t) \rangle$ .
- (D) Suppose there are  $M$  signals, each of which is synthesized via  $\{f_i(t)\}_{i=1}^{\infty}$  with coefficients  $\vec{s}_m = (s_{m,1}, s_{m,2}, \dots)$ , i.e.,  $s_m(t) = \sum_{i=1}^{\infty} s_{m,i} \cdot f_i(t)$  for  $1 \leq m \leq M$ . Then, the minimum Euclidean distance decision rule, i.e.,

$$\arg \min_{1 \leq m \leq M} \|\vec{r} - \vec{s}_m\|^2 = \arg \min_{1 \leq m \leq M} \sum_{i=1}^{\infty} (r_i - s_{m,i})^2,$$

is equivalent to the minimum inner-product decision rule below:

$$\arg \min_{1 \leq m \leq M} \langle r(t) - s_m(t), r(t) - s_m(t) \rangle,$$

provided  $r(t) = \sum_{i=1}^{\infty} r_i f_i(t)$ .

- (E) The minimum inner-product decision rule

$$\arg \min_{1 \leq m \leq M} \langle r(t) - s_m(t), r(t) - s_m(t) \rangle$$

is equivalent to

$$\arg \max_{1 \leq m \leq M} \langle r(t), s_m(t) \rangle.$$

參考用